

# Standard Bracing of Simple Duopitched Trussed Rafter Roofs for Dwellings

A Trussed Rafter Association Product Data Sheet  
Sheet No.4



*Harlow*

TIMBER SYSTEMS

Harlow Timber Systems Ltd  
Walker Rd  
Forest Business Park  
Bardon Hill  
Coalville  
Leicestershire  
LE67 1TU

t 01530 516990

f 01530 516991

e [hts@harlowts.co.uk](mailto:hts@harlowts.co.uk)

w [www.harlowts.co.uk](http://www.harlowts.co.uk)

Registered No 1801353 England

Vat No 395 6607 09





# Trussed Rafter Association

## Product Data Sheet

Sheet No.4 - August 2002

## Standard Bracing of Simple Duopitched Trussed Rafter Roofs for Dwellings

### Why brace trussed rafter roofs?

Trussed rafters must be braced to create a rigid and stable roof structure. If the bracing is omitted, wrongly positioned or badly fixed, it may result in distortion or failure of individual trusses or in some instances the whole roof.

### Bracing Responsibility

The Building Designer and not the trussed rafter supplier is responsible for designing and detailing all elements of roof bracing required in the roof including any bracing required by the truss designer in order to provide lateral restraint to truss members. The Trussed Rafter Designer will inform the Building Designer of any truss integrity bracing required, eg compression web braces.

The bracing system shown in this Product Data Sheet is taken from BS 5268-3, 'Code of practice for trussed rafter roofs', and shows a standard method of providing roof stability for spans up to 12 m.

The system of bracing reproduced in this Data Sheet may be used without any further calculations, provided that the limitations summarised are met in full.

### The Functions of Roof Bracing

Roof bracing performs three distinct functions:

#### Temporary bracing

This is used to restrain the trusses during erection. See Product Data Sheet No.3 for more information.

#### Truss Stability bracing

This is permanent bracing which holds the trusses upright, straight and prevents any out-of-plane buckling of the members.

#### Wind or wall bracing

This bracing is installed in the roof in addition to the truss stability bracing and its purpose is to stabilise the gable walls under the action of wind loading.

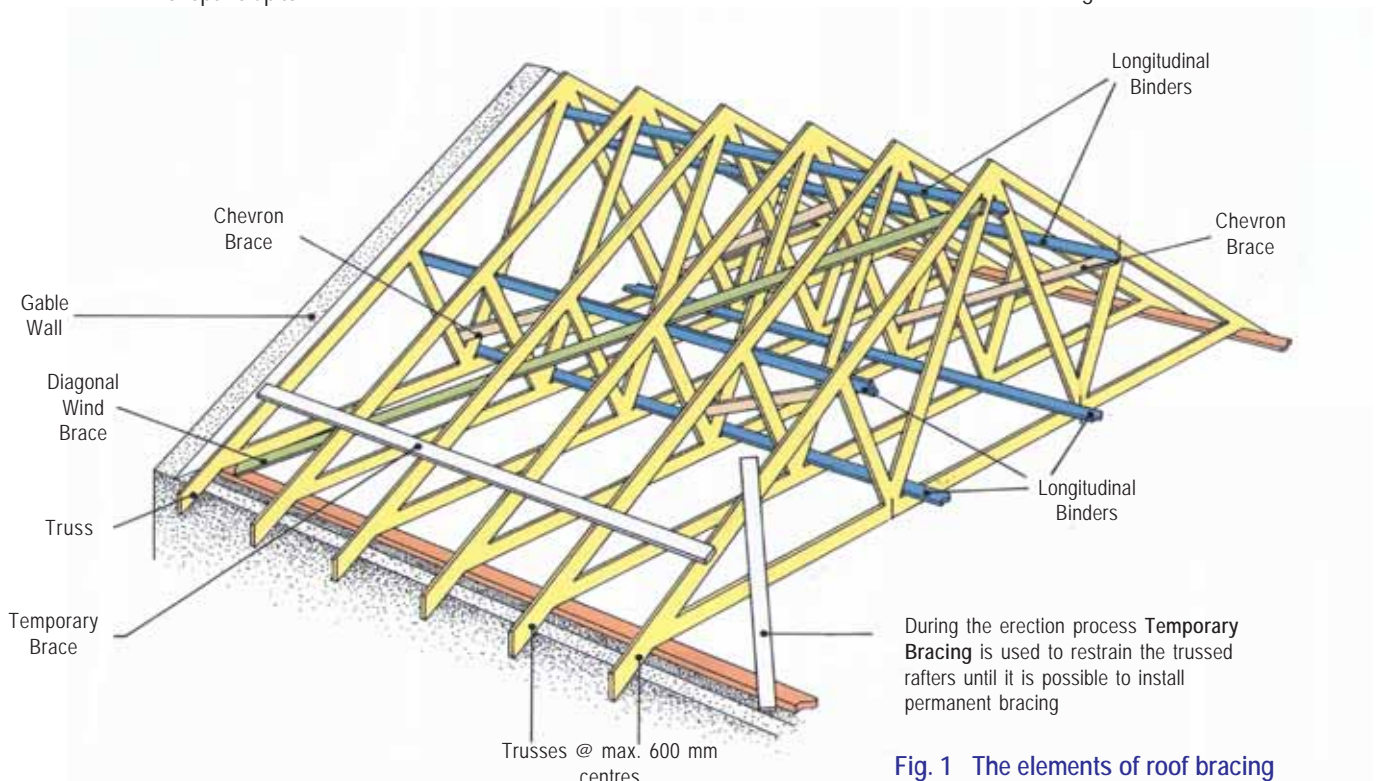

Fig. 1 The elements of roof bracing

## Application of Standard Bracing

The standard bracing method given in BS 5268-3 and summarised in part in this Product Data Sheet is for use in the bracing of trussed rafter roofs up to 12 m in span. The use of this system, however, is dependent upon the wind loads imposed on the roof and Table 1 (see page 4) shows how the allowable span of the roof is affected by the building's exposure to wind speed.

Notwithstanding Table 1, the use of this standard bracing method does not apply to buildings erected upon long stretches of open, fairly level country with no shelter such as flat coastal fringes, fens, airfields or large open areas of fen, moor or farmland.

## Conditions of Use

In using this standard method of roof bracing the following conditions must be observed:

- For masonry walls the maximum unsupported length must not exceed 9 m between returns, buttresses or chimneys.
  - The masonry wall must be at least 180 mm thick for solid walls and 190 mm for cavity walls.
  - The maximum trussed rafter spacing is not to exceed 600 mm.
  - Maximum floor to ceiling height is 2.6 m.
  - Plasterboard ceilings of 9.5 mm or 12 mm for trusses at 450 centres or 600 mm centres respectively.
  - Bracing members to be 89 mm min. width with 22 mm min. depth with a 2134 mm<sup>2</sup> min. cross sectional area nailed to every adjacent trussed rafter with 2 x 3.35 mm diameter galvanised wire nails with a length at least 32 mm longer than the bracing thickness (normally 65mm long nails are used). Nails should be no closer than 50 mm to the cut end of any brace.
- NOTE:** 3.1mm machine nails may be used in lieu of 3.35mm standard wire nails.
- Bracing members may be jointed by overlapping over at least two trussed rafters.

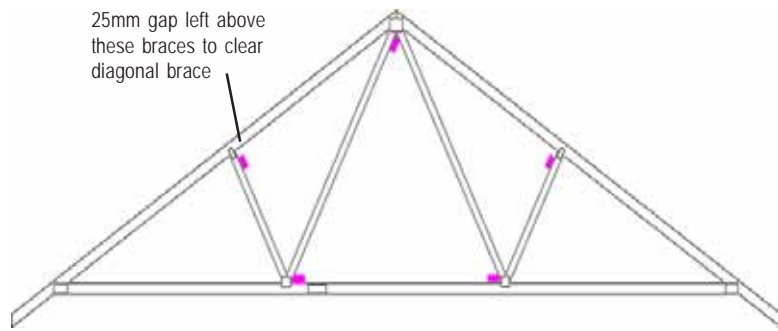

Fig. 2 Positions of longitudinal braces

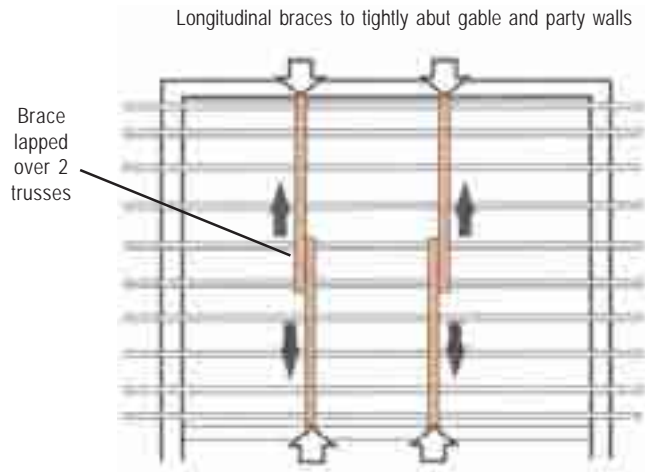

Fig. 3 The fixing of longitudinal braces

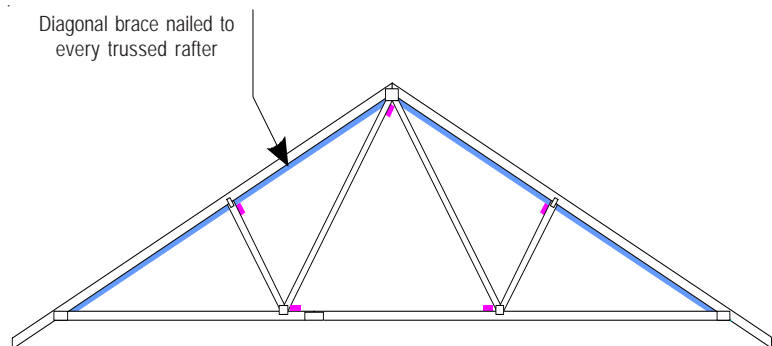

Fig. 4 Position of diagonal wind braces

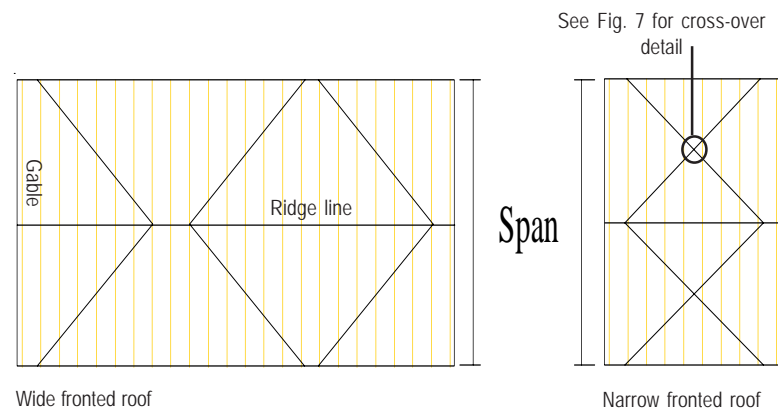

Fig. 5 Plan of rafter diagonal bracing on differing plan shapes

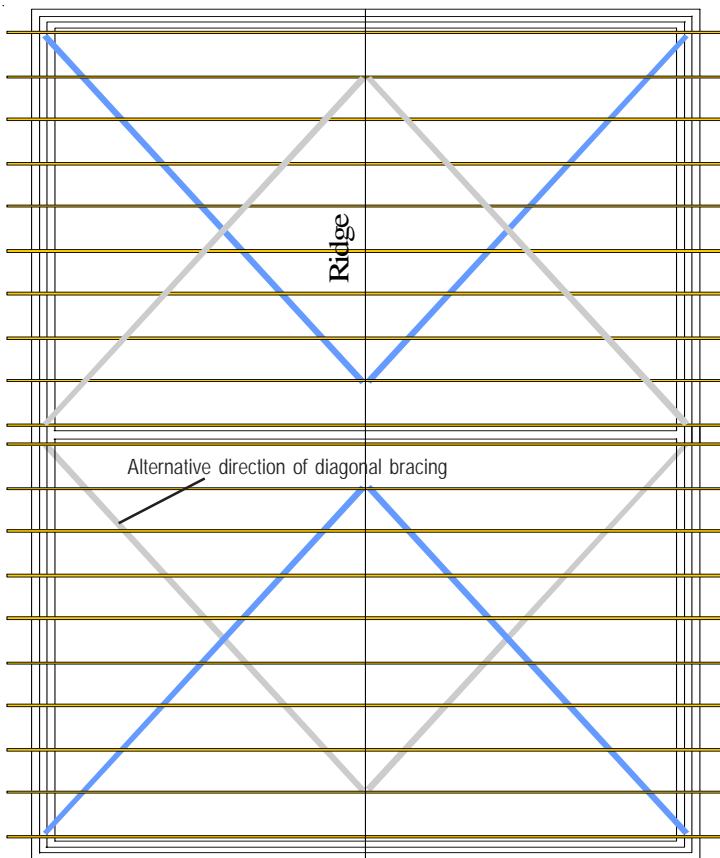

Fig. 6 Plan of rafter diagonal bracing arrangement on a wide fronted roof

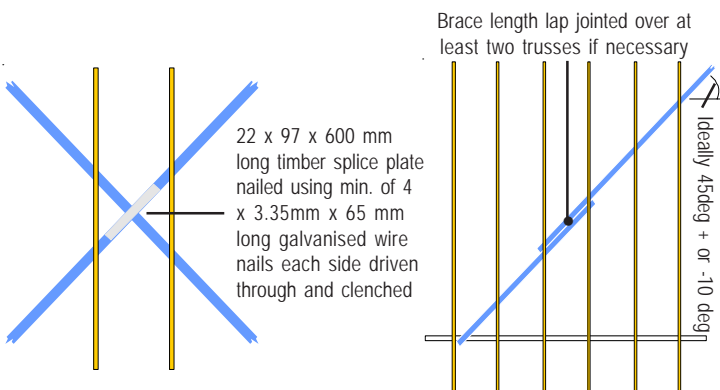

Fig. 7 Splicing of intersecting diagonal braces and end jointing

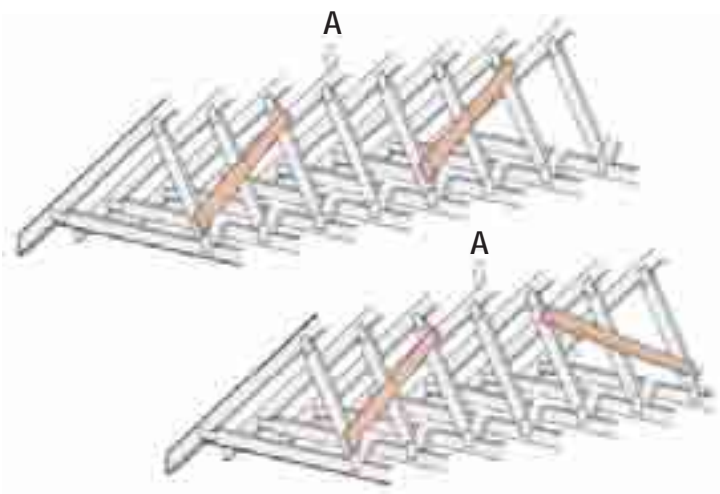

Fig. 8 Alternative fixing arrangement for chevron braces (truss span over 8m)

- At least 4 rafter diagonal braces (see Fig. 1) are fixed to the underside of rafters at approx. 45°.
- Longitudinal bracing (see Fig. 1) is located at all node points (including the apex but excluding support points).
- Other such bracing as may be required by the truss designer should be incorporated.
- Chevron bracing (see Figs 1 & 8) should be included for spans over 8 m.
- Attention is drawn to the need for lateral restraint straps to brickwork in accordance with the Building Regulations.

### Other considerations

If an insulation material is installed on top of the rafters it may reduce the effect of the tiling batten restraint to rafters. Additional bracing may, therefore, be required underneath the rafter as specified by the truss designer.

Plasterboard should be fixed directly to the face of the ceiling tie members of the trussed rafters or continuous counter battens.

Where plasterboard is omitted the ceiling tie members need to be braced at all nodes and one or more additional longitudinal brace may be required in the bays as determined by the trussed rafter design. Diagonal bracing in the outer ceiling tie bays should also be fixed at 45deg and extend the length of the building.

### Chevron bracing

Chevron bracing is needed to ensure stability on duopitch roof spans over 8m and monopitch roof spans over 5m span. The arrangement of the braces are shown in Fig. 8.

Braces need not overlap along the roof and one or two trussed rafters may be left (at position A in Fig. 8) between the ends of adjacent braces. Braces should be at about 45 degrees and be nailed to at least 3 trussed rafters.

### Roof sarking

Where approved sarking materials are directly fixed to the top face of the rafter members, it is permissible to omit the rafter diagonal bracing, chevron bracing on webs and longitudinal bracing at rafter level.

Sarking / Sheathing material must be moisture resistant and provide an adequate level of restraint to out-of-plane buckling and wind forces. See BS5268-3 for more information on suitable materials

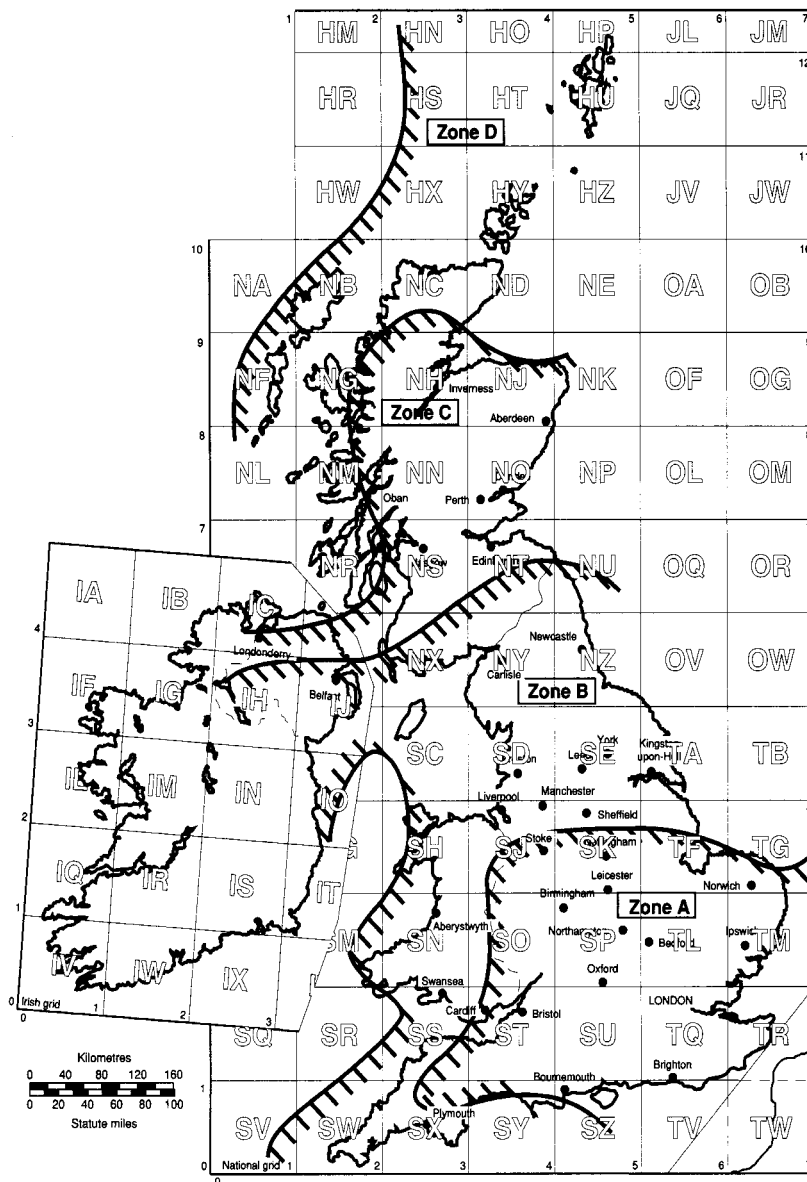

Fig. 9 Basic wind zones

	Pitch Degrees	Roof span (m)			
		Zone			
		A	B	C	D
Single storey - ceiling under roof 3.0m max above ground level	15.0	12.0	12.0	12.0	12.0
	17.5	12.0	12.0	12.0	12.0
	20.0	12.0	12.0	12.0	12.0
	22.5	12.0	12.0	12.0	12.0
	25.0	12.0	12.0	12.0	12.0
	27.5	12.0	12.0	12.0	11.5
	30.0	12.0	12.0	11.6	10.2
	32.5	12.0	11.8	10.4	9.0
	35.0	12.0	10.6	9.8	8.6
	37.5	11.5	10.0	8.7	7.5
Two storey - ceiling under roof 5.7m max above ground level	15.0	12.0	12.0	12.0	12.0
	17.5	12.0	12.0	12.0	12.0
	20.0	12.0	12.0	12.0	12.0
	22.5	12.0	12.0	12.0	12.0
	25.0	12.0	12.0	12.0	10.5
	27.5	12.0	12.0	10.6	9.9
	30.0	12.0	11.5	10.0	8.7
	32.5	11.8	10.2	8.9	7.6
	35.0	10.5	9.1	7.7	7.2
	37.5	10.0	8.6	7.4	6.2
Three storey - ceiling under roof 8.4m max above ground level	15.0	12.0	12.0	12.0	12.0
	17.5	12.0	12.0	12.0	12.0
	20.0	12.0	12.0	12.0	11.9
	22.5	12.0	12.0	12.0	10.4
	25.0	12.0	12.0	10.5	9.1
	27.5	12.0	11.5	10.0	8.6
	30.0	11.8	10.2	8.8	7.5
	32.5	10.5	9.0	7.6	7.1
	35.0	10.0	8.5	7.2	6.0
	37.5	8.9	7.5	6.2	5.8
40.0	7.7	7.1	5.9	4.8	
42.5	7.4	6.1	4.9	4.6	
45.0	6.3	5.8	4.7	4.4	

Table 1 Limiting spans for standard bracing

This information sheet gives a summary of the standard bracing requirements given in BS 5268-3. All the information given here should be read in conjunction with the requirements of that standard. The guidelines contained within this information sheet are given in good faith but without liability and its use shall be entirely at the risk of the user.

For more information on the bracing of trussed rafter roofs readers are recommended to study BS 5268 - 3, "Structural use of timber - Code of

practice for trussed rafter roofs" available from the British Standards Institution. Figure A4 from BS 5268-3 is reproduced with the permission of BSI under licence number 2002SK/0190. British Standards can be obtained from BSI Customer Services, 389 Chiswick High Road, London W4 4AL. (Tel + 44 (0) 20 8996 9001).

Further detailed reading on bracing methods can also be found in the 'Technical Handbook - Site Installation Guide' available from the Trussed Rafter Association, priced at £5 per copy (Remittance with order please).



**Trussed Rafter Association**

PO BOX 571  
Chesterfield  
S40 9DH

Telephone & Fax: 01246 230036  
e-mail: [info@tra.org.uk](mailto:info@tra.org.uk)  
website: <http://www.tra.org.uk>